

ISU FISHERIES EXTENSION

Managing Iowa Fisheries

Cage Fish Culture

What is Cage Culture?

Fish are raised commercially in one of four culture settings: open ponds, raceways, tanks, or cages. Cage culture of fish uses existing water resources but encloses the fish in a cage or basket that allows water to pass freely between the fish and the pond.

The origins of cage culture are vague. It is likely that the first cages were used by fishermen as holding structures until enough fish could be accumulated for market. The first true cages for producing fish were developed in Southeast Asia around the end of the last century. These early cages were constructed of wood or bamboo, and the fish were fed trash fish and food scraps.

Modern cage culture began in the 1950s with the advent of synthetic materials for cage construction. In the United States, universities began conducting research on cage rearing of fish in the 1960s. Cage research has been limited mostly because large-scale open pond culture was more economically viable and, therefore, received most of the research focus.

Today cage culture is receiving more attention by both researchers and commercial producers. Factors such as increasing consumption of fish, some declining wild fish stocks, and a poor farm economy have produced a strong interest in fish production in cages. Many of America's small or limited resource farmers are looking for alternatives to traditional agricultural crops. Aquaculture is a rapidly expanding industry and one that may offer opportunities even on a small scale. Cage culture also offers the farmer a chance to use existing water resources that in most cases have only limited use for other purposes.

Cage culture of fish is not foolproof or simple. To the contrary, cage production can be more intensive in many ways than pond culture and should be considered as a commercial alternative only where open pond culture is not practical.

Considerations for Cage Culture

As with any production scheme cage culture of fish has advantages and disadvantages that should be considered carefully before cage production becomes the chosen method.

Advantages

Cage culture does have some distinct advantages that include:

- Many types of water resources can be used, including lakes, reservoirs, ponds, strip pits, streams, and rivers that could otherwise not be harvested. (Specific state laws may restrict the use of "public waters" for fish production; check with your state fish and wildlife agency.)
- A relatively low initial investment is all that is required in an existing body of water.
- Harvesting is simplified.
- Observation and sampling of fish is simplified.
- Use of the pond for sport fishing or the culture of other species.

These advantages are appealing. A potential fish farmer can produce fish in an existing pond without destroying its sportfishing; does not have to invest large amounts of capital for construction or equipment; and can, therefore, try fish culture without unreasonable risks.

Disadvantages

Cage culture also has some distinct disadvantages. These include:

- Feed must be nutritionally complete and kept fresh.
- Low Dissolved Oxygen (DO) is an ever present problem and may require mechanical aeration.
- The incidence of disease can be high and diseases may spread rapidly.
- Vandalism or poaching is a potential problem.

The potential for loss of fish due to poor nutrition, low DO, disease, and poaching is real and should not be taken lightly. Feeds must be complete and provide all the necessary proteins, carbohydrates, fats, vitamins, and minerals needed for growth and health. Feeds cannot be allowed to deteriorate during storage. Low DO may occur within a cage and not affect the free-swimming fish in the pond. Because fish in cages are crowded and confined, aeration may be more necessary for a cage system than it would be if the fish were loose in the pond. Diseases must be identified and treated rapidly. Vandalism is a problem that must be anticipated and precautions must be taken. It should be emphasized that cages do not increase the amount of fish (i.e. pounds) that can be produced in a pond. This is particularly true in ponds with wild fish populations.

Species selection

Research in the United States on production of freshwater fish in cages has centered primarily on channel catfish and rainbow trout. Other species such as hybrid sunfish, hybrid striped bass, bullhead, and blue catfish have received some attention and may have potential for cage production. Before attempting to raise any species in cages, a careful examination of the site, water quality, construction costs, market outlets and legal requirements should be considered.

Site Selection and Water Quality

Ponds are not always suitable for cage culture of fish. Many failures in cage production have occurred because of poor site selection. Before venturing into cage culture, make sure your pond will support the increased biological load that cage culture will cause on its systems.

Site criteria

Many different sites may be adapted to cage culture. Potential sites include lakes, reservoirs, ponds, strip pits, rivers, and streams. Each state may have specific laws governing the use of “public waters.” These laws may restrict private individuals from engaging in fish farming in public waters or may require permits for use of public waters. Check with the Department of Natural Resources or with the Cooperative Extension Service’s fisheries/aquaculture specialist in your state before using public waters for aquaculture.

Many ponds and strip pits are not suitable for culturing fish in cages. The following are criteria that should be considered before attempting cage culture in an existing pond or strip pit.

- The surface area should be at least one half acre and preferably an acre or larger (should not include weed infested areas of the pond).
- The pond should be at least 8 feet deep over a sizeable area, and most of the pond should be more than 3 feet deep.
- The pond must have good water quality and should not be protected from prevailing winds. (See section on following page).
- The pond should not have direct access by livestock or large numbers of livestock in the watershed.
- The pond should not have a highly erosive watershed or one that allows the accumulation of large amounts of organic debris.
- The water level of the pond should not fluctuate significantly (2 to 3 feet) during the summer.
- The pond should not have chronic problems with aquatic weeds, surface scum, over-populations of wild fish, or oxygen stress problems.
- The pond should have an all-weather access road.



Ponds must support increased biological load

Pond problems

Small ponds (less than one acre) almost inevitably encounter problems. Those problems usually center on water quality deterioration, low oxygen stress, ammonia or nitrite buildup, and/or excessive algal blooms. These problems also may occur in ponds larger than one acre but are not as common. Adequate depth of the pond (8 feet or greater) is important for keeping the fish wastes away from the cage, maintaining adequate circulation through the cage, and for reducing the chance of weed encroachment around the cage.

The characteristics of the pond's watershed can be critical to successful cage culture. Livestock with direct access to, or located in large numbers within the watershed of the pond, may cause water quality problems. Livestock wastes can over fertilize the pond leading to severe algal blooms, water quality deterioration, and eventually disaster. This is particularly true of small ponds (less than 5 acres). Livestock need to be fenced out of the pond and not allowed to use the immediate pond watershed as a loafing area. As shorelines are trampled, erosion increases and ponds age prematurely. Even ponds frequented by livestock in previous years may contain large amounts of organic matter.

Highly erosive watershed may cause turbidity problems that can irritate the gills of fish and cause reduced oxygen levels. Watersheds that allow large amounts of organic matter to wash into the pond can result in oxygen depletions due to rapid bacterial decomposition of the detritus (organic matter).

Ponds that have a greater watershed than is needed to fill and maintain the water level also can have problems. Excessively large watersheds can cause rapid temperature changes, turnovers, and associated oxygen depletions due to water exchanges after heavy rains.

Ponds that have chronic problems such as severe weed infestations, surface scum, fish kills, stunted wild fish populations, and severe water level changes during the summer are not good candidates for cage culture. These problems must be brought under control first. It may be necessary to treat chemically for weeds or to stock grass carp, remove wild fish, and/or renovate (rebuild) the pond. Finally, an all-weather access road to the pond is essential to the maintenance, health, and survival of the caged fish. A day or more without access may lead to an unnecessary catastrophe.

Water quality

Water quality should be adequate for fish survival. Dissolved oxygen, pH, temperature, and ammonia levels should be considered prior to and continuing through the culture period. Further detail on water quality may be obtained from ISU publication PM 1352A, Water Quality: Managing Iowa Fisheries, or on the web at www.extension.iastate.edu/fisheries/publications/PM1352A.pdf.

Cage Construction and Placement

Cages for fish culture have been constructed from a variety of materials and in practically every shape and size imaginable. Basic cage construction requires that cage materials be strong, durable, and non-toxic. The cage must retain the fish yet allow maximum circulation of water through the cage. Adequate water circulation is critical to the health of the fish, in bringing oxygen into the cage, and removing metabolic wastes from the cage. Location of the cage in the pond may be critical to proper circulation through the cage. Mechanical circulation and aeration through the cage may be necessary if stocking densities are high, cages are large, or water quality deteriorates during production.

Cage materials

Cage components consist of a frame, mesh or netting, feeding ring, lid, and flotation. Cage shape may be round, square, or rectangular. Shape does not appear to affect production.

Cage size depends on the size of the pond, the availability of aeration, and the method of harvest. Most fish farming supply companies sell manufactured cages, cage kits, or materials for constructing cages. The most common cage sizes used in ponds are: cylindrical—4 x 4 feet; square—4 x 4 x 4 feet and 8 x 8 x 4 feet; and rectangular—3 x 4 x 3 feet and 8 x 4 x 4 feet.

The frame of the cage can be constructed from wood (preferably redwood or cypress), iron, steel, aluminum, fiberglass, or PVC. Frames of wood, iron, and steel (unless galvanized) should be coated with a water-resistant substance like epoxy, or an asphalt-based or swimming pool paint. Bolts or other fasteners used to construct the cage should be of rust-resistant materials.

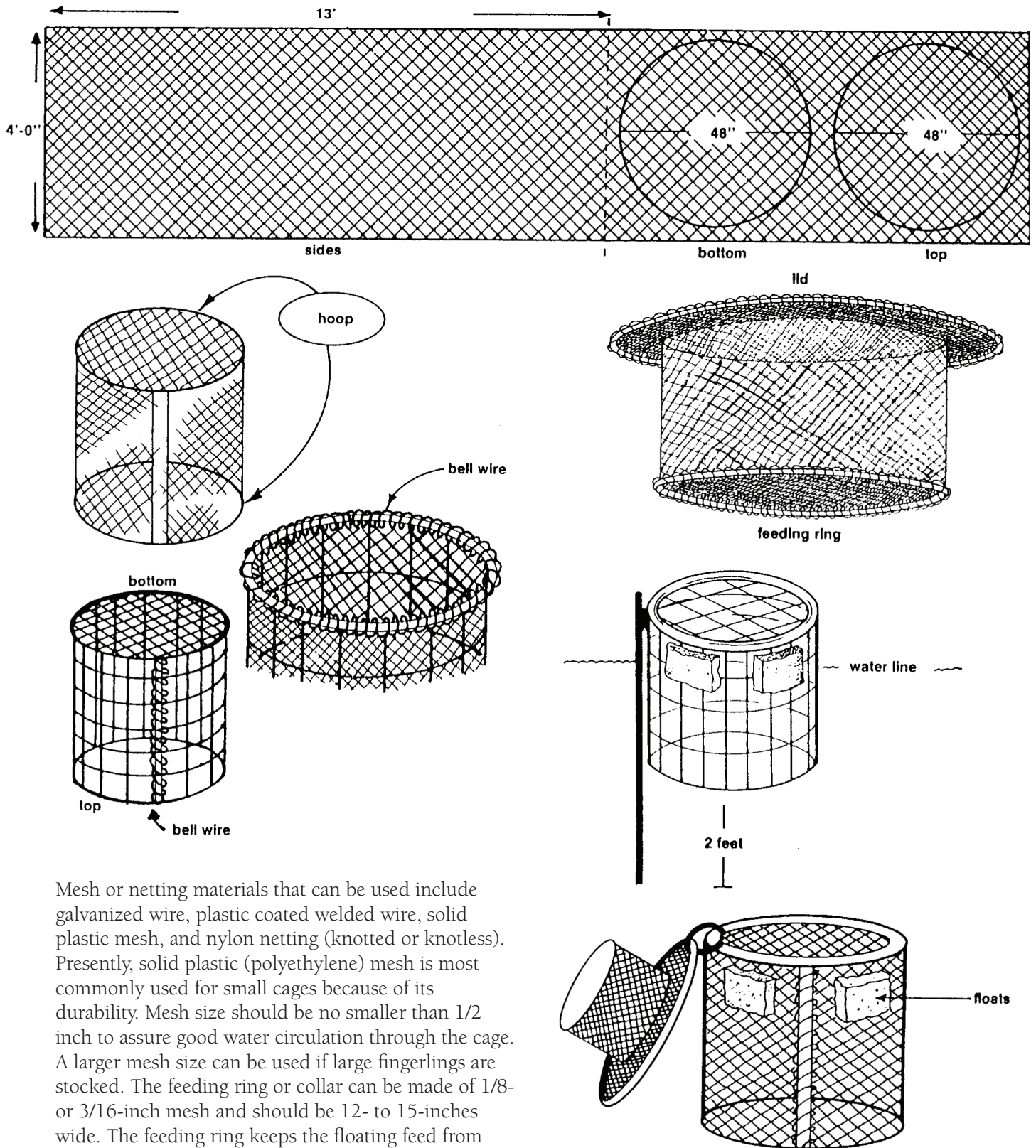

Mesh or netting materials that can be used include galvanized wire, plastic coated welded wire, solid plastic mesh, and nylon netting (knotted or knotless). Presently, solid plastic (polyethylene) mesh is most commonly used for small cages because of its durability. Mesh size should be no smaller than 1/2 inch to assure good water circulation through the cage. A larger mesh size can be used if large fingerlings are stocked. The feeding ring or collar can be made of 1/8- or 3/16-inch mesh and should be 12- to 15-inches wide. The feeding ring keeps the floating feed from washing through the cage sides.

All cages should have lids so fish cannot escape and predators (including people) do not enter the cage. Lids may be made from the same material as the rest of the cage or from other materials, such as

Figure 1: Standard Cage

plywood, Masonite, or light gauge aluminum or steel. Plywood, Masonite and steel will need to be painted with exterior or epoxy paint. Some cage enthusiasts believe that opaque lids (particularly in clear ponds) reduce stress on fish by limiting their visual contact with outside disturbances. No scientific research has been performed to support or dispute this observation. The manager of the cage, however, needs to be able to observe feeding behavior and have easy access to remove uneaten feed and any dead fish.

Flotation of the cage can be provided by inner tubes, styrofoam, waterproofed foam rubber, capped PVC pipe, or plastic bottles. Cages also can be suspended from docks. Plastic bottles should be made of sturdy plastic (e.g., antifreeze or bleach bottles) and should have their caps waterproofed with silicon sealer. Floats should be placed around the cage so that it floats evenly with the lid about 6 inches out of the water.

Cage construction

The simplest cage design to construct is a 4 x 4 ft cylindrical cage fashioned from 1/2-inch plastic mesh (fig. 1). The mesh comes in a roll 4 feet wide by 50 feet long. A total of 21 feet of plastic mesh is used per cage. Thirteen feet of mesh is used for the cylinder with two 4-foot panels for the bottom and lid. The plastic mesh is easily cut with tin snips. The cylinder is formed around two metals, PVC, or fiberglass hoops at the top and bottom of the cage. A third hoop is used to form the lid.

The cage can be laced together with 18-gauge bell wire (plastic coated solid copper wire), stainless steel wire, galvanized wire, hog rings, or black plastic cable ties (white cable ties should not be used as they deteriorate in sunlight). Form the cylinder around two of the hoops and hold them in place temporarily with short pieces of wire. Lace the top hoop to the end of the cylinder making sure that no holes or gaps are present between the hoop and the mesh. After the top is laced together, turn the cylinder over, place one of the 4-foot square mesh panels across the hoop, and attach the panel, cylinder and hoop temporarily with a few short pieces of wire. Now lace the panel (bottom), hoop, and cylinder together. Trim the surplus mesh from around the bottom using tin snips. Finally, lace the side seam of the cylinder together. It is a good idea to lace the seam together along both edges of the mesh.

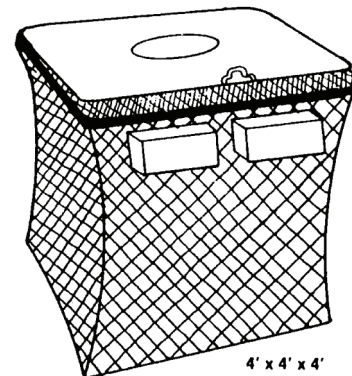
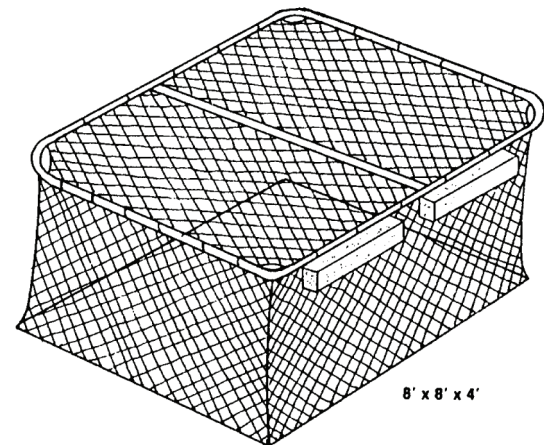
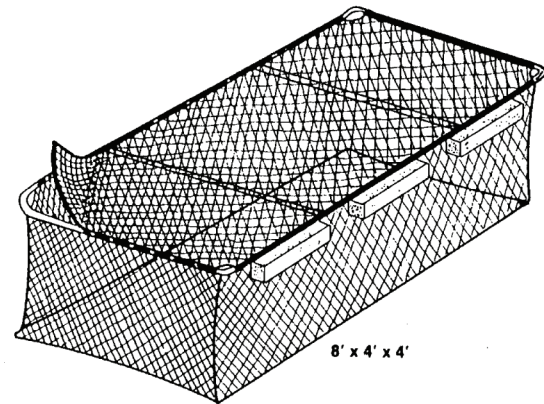
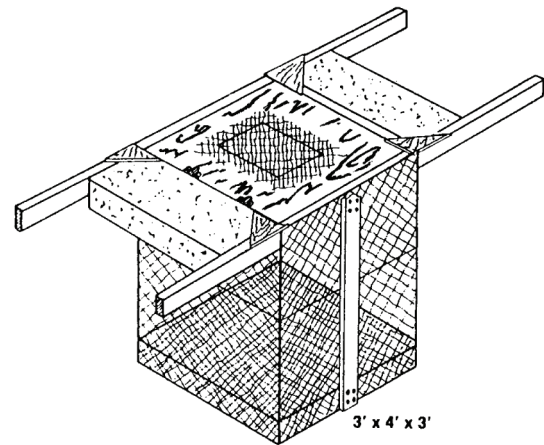

Figure 2: Perspective of Completed Cage

Lace the third hoop (lid) to the remaining 4-foot square mesh panel. Trim the mesh to form the circular lid by cutting around the outside of the hoop. Next attach the feeding ring to the inside of the cage or suspend it from the lid. Suspending the feeding ring from the lid reduces the amount of fouling around the outsides of the cage. The feeding ring is prone to fouling because of its smaller mesh size. A feeding ring attached to the side of the cage should be 12 inches wide by 13 feet long and be attached 3 inches below the top hoop. A feeding ring attached by the lid should be 15 inches wide by 8 feet long and will form a 3-foot diameter feeding area in the center of the cage. The feeding ring should be cut to the proper size and attached using bell wire. The lid can now be attached to the cage. Attach the lid to the top hoop using cable ties or wire as a hinge. After the cage is stocked, the lid should be tied securely. Finally, attach the flotation to the cage. Usually four floats equally spaced around the cage are sufficient for proper flotation. Floats should be attached securely to the cage sides with either wire or nylon rope. Attach the floats so that the cage will float with the top 6 inches out of the water. Floating at this level, the feeding ring should extend about 9 inches into the water. Flotation may not be necessary if the cage can be attached to a pier or dock.

Figure 2 shows some alternative cage designs. The basic design and construction principles previously described apply to all cages:

- Attach the netting or mesh securely to the frame.
- Lace carefully leaving no gaps or holes.
- Lids and feeding rings are essential.

Cage placement

Location of the cage in the pond may be critical to its success. Two factors to consider in cage placement are access to the cage and maintenance of water quality. Daily feeding and management of the cage necessitate easy access under almost any weather condition. Access may be by pier or by boat. Probably more critical to the success of the cage will be a location in the pond that allows for good water circulation.

Critical factors for location in an area to maximize water quality are:

- Windswept. It is important that the cage be in an area where it will receive maximum natural circulation of water through the cage. Usually this

is in an area that is swept by the prevailing winds (usually prevailing summer winds are from the southwest).

- At least 8 feet of water depth. A minimum of 2 feet of water is needed under the cage to keep cage wastes away from the fish.
- Away from coves and weed beds. Coves, weed beds, and overhanging trees can reduce wind circulation and potentially cause problems.
- Away from frequent disturbances from people and/or other animals (e.g., dogs, ducks, etc.). Disturbances from people frequently walking on the dock, fishing, or swimming near the cage, and/or from animals which frequent that area of the pond will excite the fish and can cause stress, injury, reduced feeding, and secondary disease. Fish are shy creatures and should never be disturbed needlessly.
- At least 10 feet from other cages. Cages should not be too close together. Close proximity to other cages may increase the likelihood of low dissolved oxygen. Access to electricity or to a location where a tractor-driven paddle wheel, irrigation pump, or other aeration device can deliver aerated water to the cages should be considered before locating cages. Aeration devices should move oxygenated water through the cages. Locating cages at too great a distance from supplemental aeration can negate any effectiveness.

Larger cages

Cages larger than the ones described here have been built and used in large lakes, reservoirs, rivers, bays, and estuaries. Many times large cages are called net pens because they are constructed from nylon netting. Today several states are conducting research and demonstrations on large cages for ponds that have built-in aeration devices. Not enough research has been done at this time on these systems to warrant recommendation. It would appear, however, that large cages can be designed that will maximize the number of fish sustainable by the pond and actually support increased densities above present recommended levels.

Species Suitable For Cage Culture

Many species of fish are suitable for cage culture. Species that have been researched and successfully reared in cages include: catfish, trout, hybrid striped bass, and bluegill sunfish. Other species may be suitable for cage culture, but research has lagged behind other aquaculture research in recent years.

Interest in cage culture has been revived as an alternative crop for farmers outside the traditional fish farming areas and in areas with topography not conducive to levee ponds. As this interest continues to increase, more research into cage culture techniques and alternate species will no doubt occur.

A great deal of variability exists in the research and commercial literature about suitable pond sizes, growing season, stocking densities, and size of fingerlings to stock. Stocking rates or densities are dependent on species, cage size, pond surface area, availability of aeration, and desired market size. In general, stocking densities are calculated on the number of pounds of fish that can be reared per surface acre of pond and per cubic foot of cage. A pond without aeration can produce from 500 to 1,500 pounds of fish per surface acre. In a pond with aeration, 2,500 to 4,000 pounds of fish per acre are possible. The maximum pounds of production per cubic foot of cage seldom exceed 14 pounds in small cages and 11 pounds in large cages (< 270 cubic feet).

Cage production is possible in ponds, lakes, reservoirs, strip pits, rivers, and streams, and in cages that range in size from 1 cubic yard to several hundred cubic yards (in large reservoirs). In this fact sheet ponds will be the frame of reference and only cages smaller than 10 cubic yards (270 cubic feet) will be considered.



Stocking rates are different for each species.

Catfish

The channel catfish is the species most commonly cage-cultured today. Channel catfish have a well established market; fingerlings are generally available; they tolerate many extremes in water quality; and they readily adapt to cages.

Channel catfish are warmwater fish. Optimum growing temperature for channel catfish is between 80° and 85° F. Good growth occurs between 70° and 90° F. Above 90° F fish reduce feeding and deaths may occur. Below 70° F feeding slows and, therefore, growth slows. Feeding essentially stops below 50° F. It should be noted that channel catfish growth is limited in the Midwest due to their warm water requirements. Thus, culture of this species will be limited in this region.

Channel catfish should be stocked only in a certain range of water temperatures. Handling stress associated with stocking and quality of fingerlings stocked are critical factors to be considered. Channel catfish can be stocked into cages almost any time when the water temperature is above 50° F. However, stocking at temperatures above 80° F may adversely stress the fish and lead to disease and possibly death. Stocking poor quality fingerlings before the water reaches 60° F (when predictable feeding occurs) can lead to handling stress compounded by nutritional stress from the lack of food intake. For these reasons it is probably best to stock when water temperatures are between 60° and 70° F. Of course, fish farmers may have to learn how to handle and stock fingerlings at any range of temperatures to be competitive and meet their marketing objectives.

Size of catfish fingerlings to be stocked depends on the length of growing season, availability, and marketing strategy. The minimum size fingerling that can be stocked into a cage made of 1/2-inch mesh is 4 to 5 inches. Generally 6- to 8-inch fingerlings are stocked into cages. If a 1 1/4- to 1 1/2-pound fish is the desired market size at harvest, it may be necessary to stock a larger fingerling or stock at a lower stocking rate. A larger fingerling must be stocked in the regions (or at high elevations) where the growing season is shorter. It is not uncommon to stock 8- to 10-inch fingerlings where the growing season is 180 days or less (as in the Midwest). Availability and cost of larger fingerlings may make stocking these sizes prohibitive. A fingerling over 10 inches in length will not adapt well to a cage.

Stocking densities for catfish fingerlings in cages range from 6 to 14 per cubic foot of cage. This equates to 250 to 600 fish in a 4 x 4 feet cylindrical cage. Generally, it is best to stock at the low densities (7 to 9 per cubic foot) when first attempting cage culture and particularly if supplemental aeration is not present. Do not stock below a density of 6 per cubic foot or catfish will fight, leading to injury and disease. Some

recommended stocking rates for small cages are given in table 1. Even with supplemental aeration available, it may be advantageous, for stress reasons, to stock additional cages rather than overstock individual cages. Overstocking can lead to serious growth and health problems.

Blue catfish and bullhead catfish have been stocked in cages with some success. Blue catfish do not do well in small cages and have slightly cooler temperature preference than channel catfish. Bullhead catfish have been raised in cages and appear to do well. Recommended stocking size is a 6-inch fingerling. Bullheads do not grow as large as channel catfish, however, and are expected to get to only 1/2 pound in a growing season. Fingerlings of these species are usually difficult to find and may be expensive.

Trout

Rainbow, brown, and brook trout can all be reared in cages. Rainbow trout are most often cultured because of the availability of fingerlings, established market, and adaptability to cages. Basic culture of all three species is very similar. Rainbow trout will be described here, but the information should apply to other trout species.

Trout are coldwater species. Optimum growth temperature for trout is between 55° and 65° F, but good growth is attained between 50° and 68° F. At 70° F severe heat stress begins, usually followed by death if exposure is prolonged. Below 45° F feed conversion drops significantly and therefore, growth. These temperature regimes make cage culture of trout a wintertime only activity in the midwestern United States, except where cold spring water or high altitude lowers summertime water temperatures.

It is necessary to stock a 6- to 8-inch fingerling trout in most of the Midwest to obtain a 1/2- to 1-pound trout by the end of the growing season. Stocking should begin as soon as the water temperature drops below 68° F. Harvesting should begin as soon as the water warms in the spring to 68° F. Failure to harvest in time will mean loss of your product and profit.

Table 1. Recommended stocking rates for cages

Cage Size (feet)	Stocking Rates
4 x 4	300 - 400
4 x 4 x 8	400 - 500
8 x 4 x 4	800 - 1000
8 x 8 x 4	1500 - 2000

Stocking densities for trout in cages may be a little higher than those for catfish. The higher oxygen levels maintained by cooler water and smaller sizes at harvest allow trout to be stocked at the higher densities of table 1 without concern for aeration and Low DO. In fact, densities as high as 15 fish per cubic foot may be acceptable.

Striped bass

Hybrid striped bass and striped bass temperature tolerances and preferences are less than that of channel catfish. Stocking densities recommended are the same as given in table 1.

At present the greatest problem in cage culture of striped bass is the availability of large or advanced fingerlings. Most fingerlings are sold at sizes too small to be stocked into cages. A minimum 4-inch fingerling is needed for stocking and 8-inch fingerlings would be preferable. Fingerlings should be graded closely as cannibalism is a problem in young striped bass.

Bluegill

Bluegill sunfish and their hybrids have been reared in cages with some success. Temperature tolerances and preferences of bluegill are similar to those for channel catfish (described previously). Bluegill, however, are more aggressive and will take food at lower temperatures than catfish and should be stocked before the water temperatures reach 60° F.

Fingerling bluegill should be 3-to-4 inches or larger at stocking and should be graded carefully to assure uniformity. Stocking densities for bluegill are at the upper range of those given in table 1.

Handling and Feeding Caged Fish

Stress induced by handling and poor feeding practices is a common cause of cage culture problems. Handling stress occurs whenever fish are captured, moved, or confined. Handling stress is usually associated with seining, holding, hauling, or stocking fish. Problems associated with incorrect feeding practices are particularly acute in cages since no natural foods are usually available to the caged fish, and water quality deterioration from waste feed has a more direct effect on confined fish. Faulty feeding practices that are common in cage culture include: poor quality feed, incomplete feed, inadequate feeding, overfeeding, and feeding at the wrong time of the day. Many of these problems have no simple solution and some degree of

stress will occur. In most cases, the management goal must simply be to reduce the total stress placed on the fish by handling and feeding practices.

Handling

Caged fish are confined at high densities in a small area. It should be obvious, therefore, that caged fish are in a situation in which frequent stresses are likely to occur.

Most cage culturists do not start out producing their own fingerlings. If fingerlings are purchased from outside sources, it is possible that they may have already been stressed in handling. Common handling stressors during harvest, holding, and transport from fingerling ponds to the culture pond include heat or cold shock, oxygen deficiencies, high ammonia or nitrite levels, pH shock, overcrowding, and rough handling. The first encounter the fish culturist usually has with the fingerlings is at purchase. Therefore, it is at purchase that the culturist must make a determination of the fingerlings' health (i.e., quality). Stocking quality fingerlings of uniform size and free of disease is essential to successful cage production. Purchase fish from reputable producers who will guarantee their product. If possible, the fingerlings should be inspected by a certified fish disease specialist. If that is not possible, look for signs of disease and stress, such as:

- skin abrasions or discoloration, thin bodies, and variation of skin color within the group;
- condition of the fins and gills—frayed fins or pale, swollen, and eroded gills;
- odd behavior, weak or erratic swimming, piping, and lack of net avoidance.

All of these are indicators of problems. Starting with stressed or diseased fish will probably lead to disaster and not make cage culture a good experience.

Stocking into the cage is always stressful on the fish. Appropriate equipment and experience are important in transporting fish. Transport the fish in a well-oxygenated container the same temperature (within 5° F) as the water the fish were in when purchased. To reduce stress and remove certain parasites during transport, add salt to the hauling container. Stock the fish at pond temperatures that will not stress the fish. If the temperatures of the pond and the hauling water differ by more than 5° F, temper the fish by slowly adding pond water to equalize the temperature. At

least a 20-minute wait is needed for a 10° F change in water temperature. Failure to properly adjust the temperature can lead to immediate death or can lower the fingerlings' ability to resist infections and lead to secondary diseases or parasites. Finally, do not feed the fish for 1 or 2 days after stocking. Let the fish recover from the haul and adjust to the cage.

Problems that occur immediately after stocking were either brought in with the fingerlings, occurred during stocking, or are an indication of severe pond problems. A cage culturist should know the pond and its water quality before stocking, and not stock fish into a pond with problems.

During the growing season the fish should be disturbed as little as possible. Moving the cage, lifting the cage to look at the fish, netting the fish, swimming or fishing near the cage, or placing the cage where it can be disturbed by other animals can stress the fish. Stress can lead to reduced feed consumption (i.e., reduced growth) and secondary infections.

Feeding practices

Nutritional stress is common in cage culture. In fact, most of the failures of both research and commercial cage culture prior to 1975 can be related to feed quality. Today the science of fish nutrition has progressed to the point that balanced and complete diets can be formulated for the important commercial species. These complete diets are available from commercial feed mills and are essential to the health and growth of caged fish. Caged fish in most cases will receive no natural food and, therefore, must have a nutritionally complete diet that has adequate protein and energy levels, is balanced in amino acids and in essential fatty acids, and is supplemented with a complete array of vitamins and minerals. Many commercial feed mills manufacture both complete and supplemental diets. The fish farmer must purchase a complete diet—one that is suitable for the species being cultured.

Caged fish should be fed a floating pelleted feed. Floating feed is trapped inside the feeding ring and will allow the fish farmer the opportunity to observe the fish. Sinking feed will fall through the cage (unless the cage has a bottom) and not be eaten by the fish. In general, warmwater species such as catfish, hybrid striped bass, and bluegill can be successfully reared from large-sized fingerlings on 32 percent protein complete diets although many fish farmers prefer 36 percent. Coldwater species such as trout need a higher

Table 2. Estimated consumption by various sizes of channel catfish when water temperature is above 70° F.*

Average weight/length per fish (pounds/inches)	% Body weight consumed
0.02/4	5.00
0.04/5	4.00
0.06/6	3.00
0.25/9.5	2.75
0.50/12	2.50
0.75/13.5	2.25
1.00/15	2.00
1.50/17	1.75

* Applicable to most warmwater species.

protein diet of 40 to 42 percent. Pellet sizes normally available include 1/8, 3/16, and 1/4-inch diameter. Usually large fingerlings can accept 1/4-inch pellets. Small fingerlings and species with small mouths (e.g., bluegill) may need to be started on 1/8-inch pellets.

Many cage culturists anticipate problems and are prepared to feed medicated feed for the first 14 days after stocking as a precaution against bacterial infections caused by handling stress. This is unnecessary if the fingerlings can be certified disease free, if the origin and quality is known, and if no hauling or stocking problems were encountered. Commercially prepared medicated feed is hard to find in many areas and you may need to mix your own medicated feed using Terramycin (oxytetracycline).

Fish will feed most aggressively near their preferred or optimum temperature and when oxygen levels are high (e.g., above 60 percent of saturation).

Oxygen is usually at acceptable levels (unless heavily overcast) between mid morning and late afternoon. From a temperature standpoint, warmwater fish such as catfish will feed better as the temperature rises in late afternoon in the spring, but prefer mid morning during the heat of the summer. Generally fish will adapt to any feeding time as long as it is consistent. Changes in the feeding schedule should be made gradually (e.g., not changing more than 30 minutes per day). Most studies have shown that fish will grow faster and have better feed conversion if their daily feed ration is divided into two feedings given at least 6 hours apart. This is particularly true of small catfish fingerlings, trout, and bluegill.

Feeding rates

Feeding rates for fish are calculated on a percent of body weight per day basis, based on the fish size and water temperature. Small fish consume a larger percentage of their body weight than larger fish, and all fish increase consumption as water temperature rises approaching optimum temperature. Small fingerlings will usually eat 4 to 5 percent of their body weight. After they reach advanced fingerling size, the rate will decrease to 3 percent and nearing harvest size will drop to only 2 percent or less (see table 2).

Correctly feeding the proper amount of feed is very important. Overfeeding wastes feed and money, and can cause water quality deterioration leading to stress and potential secondary diseases or parasites. Underfeeding reduces the growth rate, production, and profit. A general rule of thumb for most warmwater fish is to feed them all they will eat in 10 to 15 minutes when the water temperature is above 70° F. Aggressively feeding fish should consume all they will eat in 5 minutes. However, caged fish are sometimes very shy and may not start feeding immediately. Also, when fish are first stocked into a cage they usually adjust slowly to feeding. Trout should be fed all they will eat in 20 to 30 minutes. Fish in cages should be fed at least 6 days a week. The daily amount of feed fed will need to be increased as the fish grow. Feeding should be discontinued during periods of heavy overcast weather and if water temperatures exceed 90° F.

Experienced cage culturists prefer to estimate feeding rates. There are two methods commonly used to determine proper feed amounts. One method estimates growth based on feed conversion and adjusts feeding rates weekly to this estimate. The second method estimates growth based on a sample of fish from the cage and adjusts feeding rates based on this sample.

Feed conversion method

This method requires that the initial weight of the fish stocked be known and that records be kept on the total weight of feed fed each week.

For the first week, start by determining the average individual stocking weight of the fish (total weight of fish stocked in pounds divided by number of fish stocked). Using table 2, find the percent body weight that fish that size should consume. Multiply the percent body weight by the total weight of fish stocked into the cage. This gives the amount of feed that should be consumed each day for the first week.

A new estimate should be recalculated each week, based on estimated growth. Estimated growth is calculated by multiplying the total amount of feed (in pounds) fed during the week by the estimated feed conversion ratio (FCR) of 1.0/1.8 (1 pound of gain for each 1.8 pounds of feed eaten or 0.556). This estimated growth weight is added to the total weight at the beginning of the week. This new total weight is divided by the number of fish (less any deaths) to get a new weight of individual fish. Using Table 2, get the estimated percent body weight the fish should now consume and multiply this by the total cage weight. This is the new amount of feed that should be fed daily for the next week. This sounds complicated but with a little practice it becomes easy. The following formulas and example should help.

In this example the fish were averaging 1/2 pound (0.5) each at week 10 and there had been no deaths; therefore, 300 fish x 0.5 = 150 pounds = total cage weight. At that cage weight, they were consuming 3.75 pounds of feed each day for 6 days or 22.5 pounds of feed during the week. Consuming 22.5 pounds of feed with a feed conversion of 1.0/1.8 or 0.556 gives an estimated weight gain of 12.5 pounds during week 10. Adding this 12.5 pounds of weight gain to the 150 pounds of fish (estimated) in the cage at the start of week 10, gives a new total cage weight of 162.5 pounds. Since 300 fish weigh 162.5 pounds, or 0.54 pounds each, they will eat 2.5 percent (or 2.5/100 percent = 0.025) of their body weight according to table 2. Therefore, the new feeding rate (pounds) is 162.5 x 0.025 or 4.1 pounds of feed daily. This amount should be fed each day for 6 days the next week.

Measured growth estimate

This method calculates feeding rates based on the weight of a sample of fish from the cage. This should be done at 2-week intervals and usually requires that at least 10 fish be weighed from each cage. To get the average individual fish weight, the total weight of the sample of fish is divided by the number of fish sampled. This weight is used with table 2 to estimate the percent body weight consumed. The average fish weight is multiplied by the number of fish in the cage to get the total

cage weight, which is then multiplied by the percent body weight consumed to get the new daily feeding rate. The formulas and example on the following page should aid understanding.

In this example, the fish were averaging more than a half pound (0.54) each at week 10 and there had been no deaths; therefore, 300 fish x 0.54 = 162.5 pounds = total cage weight. At 0.54 pounds each of the fish should be consuming 2.5 percent (or 2.5 divided by 100 percent = 0.025) of their body weight per day (table 2). Therefore, the new feeding rate (pounds) is 162.5 x 0.025 or 4.1 pounds of feed daily. This amount should be fed each day for the next 2 weeks.

Handling is stressful on the fish, not only those handled but the other fish in the cage trying to avoid capture. During periods of questionable water quality or extremely hot weather conditions, it may be best to avoid handling the fish and estimate the weight gain.

Finally, probably the most important aspect of feeding: Do not overfeed the pond. The pond must decompose and detoxify all organic matter that enters it. Included in this organic matter are plant materials from inside and outside the pond, runoff of nutrients from fields and pastures (possibly including livestock wastes), all fish wastes, and uneaten food. Dumping pound after pound of feed into the pond puts a tremendous burden on these natural decomposition systems that use oxygen. If the systems are overloaded, the pond

Feed Conversion Method:

Estimated wt gain = total pounds of feed consumed x 0.556 (FCR)
 New total cage wt = estimated wt gain + last week's total cage wt
 Average wt of individual fish = new total cage wt/total no. of fish in cage
 New daily feed wt = new total cage wt x % body wt consumed (Table 2)

Example for week 10, cage of 300 fish, feed 6 days per week:

Estimated wt gain (wk 10) = 22.5 x 0.556 = 12.5 pounds
 New total cage wt (wk 11) = 12.5 + 150 pounds = 162.5
 Average wt of individual fish = 162.5/300 = 0.54 pounds
 New daily feed wt = 162.5 x 0.025 (2.5/100%) = 4.1 pounds

Sampling Method:

Average wt of individual fish = wt of 10 fish/10
 New total cage wt = average wt of individual fish x number in cage
 New daily feed wt = new total cage wt x % body wt consumed (Table 1)

Example for week 10, cage of 300 fish:

Avg wt of individual fish = 5.4/10 = 0.54 (pounds)
 New total cage wt = 0.54 x 300 = 162.5
 New daily feed wt = 162.5 x 0.025 = 4.1

will become depleted of oxygen and the fish will die. Unless livestock or fertilizer runoff is a problem, the greater organic load placed on the pond is from the fish feed.

The recommended maximum pond-feeding rate is not more than 25 pounds of feed per surface acre of pond per day (25 pounds/acre/day). Even at this feeding rate problems may occur. At this feeding rate the greatest number of pounds of fish that should be cultured in cages would be 1,250 pounds/acre, calculating that a 1-pound fish will eat 2 percent of its body weight daily ($1,250 \times 0.02 = 25$).

Recommended pond feeding levels can be increased if aeration is possible. Aeration can help maintain dissolved oxygen levels and support higher decomposition rates, or at least, keep the fish alive during times of low oxygen. The recommended maximum feeding rate with aeration is 40 pounds/acre/day. At this rate the greatest number of pounds of fish that should be cultured in cages would be 2,000 pounds/acre ($2,000 \times 0.02 = 40$).

Feeding rates above these levels are practiced by many experienced cage producers. The key word is experienced. Beginning cage producers should not push their ponds until they have gained experience in water quality and general pond management. Unfortunately, pond managers usually gain this experience by killing fish.

Notes on feeds and feeding

1. Observation of the fish at feeding time is vital. Feeding behavior is the best index of overall health. Actively feeding fish indicate everything is all right, for the moment. Poor feeding behavior should always be viewed with suspicion.
2. Reduce feeding levels when water temperatures drop below 60° or above 90° F.
3. Reduce or stop feeding on heavily overcast and windless days. These weather conditions reduce oxygen production and diffusion, particularly if sequential, and can lead to low dissolved oxygen. Feeding will only complicate the problem.
4. Feed quality must be excellent. Purchase feed that is known to be complete and keep it stored in a very dry, cool place. Feed should be fed within 90 days of the manufacture date.
5. Never feed moldy or discolored feed.

6. Automatic or demand feeders are not recommended for most warmwater species because of poorer feed conversion and the need to observe the fish feeding.
7. Keep accurate records on the amount of feed fed.
8. Never feed more than 25 pounds of feed/acre/day without aeration or 40 pounds of feed/acre/day with aeration.

Cage Culture Problems

High density aquaculture has been described by the USDA as the most intensive form of agriculture practiced on a large scale in this country today. Cage culture is one of the most intense forms of aquaculture. Due to its intense nature, cage culture can have problems. Anticipation can solve at least some of them.

Signs of fish stress

One problem with most types of fish culture is that the fish are difficult to observe. Ponds are usually turbid and observation of the fish impossible. Fish are generally shy and attempt to hide from people. Sampling fish to observe them may stress the fish and lead to secondary diseases. This is why observation during feeding is critical. Feeding is the only time when the fish will readily come to the surface for observation. Cages are collections of individual fish and many times behave differently, not unlike groups of people. Some cages of fish will feed readily with people all around them. Others will wait until people are gone and all is quiet.

It is critical to watch closely and note the behavior of the fish feeding in order to recognize behavior changes. Usually changes in behavior are caused by changes in their environment (i.e., the pond) or in their health. These changes may be the first signs of stress. Learn to recognize the common signs of stress that may include:

- a reduction in the amount of food eaten,
- feeding stops suddenly,
- fish are at the surface gulping for air,
- fish are swimming erratically,
- discolorations are seen on the skin of the fish,
- dead or dying fish, and
- any other strange behaviors.

If any of the above signs appear, ask yourself why? Do not let the question go unanswered for long, or a new question can appear: Where do I bury the fish? Try to analyze the problem and come up with a solution or reason for the behavior. Here are a few possible reasons or problems that could have produced these behaviors. This is by no means a complete discussion and should be taken as only some of the possibilities.

A reduction in feeding could mean disease, parasite load, low oxygen, or one of several water quality problems (e.g., ammonia, etc.). Has the weather changed? Has the pond water color changed? If it is a heavily overcast and windless day, it may simply be a temporary low but not critical oxygen problem. If the pond is changing color or a surface scum has suddenly appeared, it also may be low oxygen (see Signs of Pond Stress that follows). A sudden halt to feeding usually suggests oxygen problems; diseases, parasites and other water quality problems usually do not disrupt all the fish immediately. Another sign of critically low oxygen is fish at the surface gulping for air (usually observed before dawn), even though everything seemed fine the day before. Aerate now—in 30 minutes it may be too late!

Skin discolorations, spots, fin erosion, erratic swimming, or other strange behaviors are usually signs of diseases or parasites. If diseases or parasites are the problem, then dead fish usually start to appear soon. A few dead fish each day usually indicate some type of slowly spreading disease or parasite problem. Progressively more dead fish each day is a sign of a very serious disease problem. Dying fish or fish with suspected diseases or parasites should be diagnosed immediately. Take a live sample of fish and a water sample to your nearest fish disease diagnostic lab.

Any disease diagnostic lab will be able to give you the best treatment alternatives for the disease or parasite. If diagnosed as an internal bacterial disease, the most practical treatment is usually to feed a medicated feed (e.g., Terramycin). If an external bacteria or parasite is the problem, a water treatment may be necessary.

Depending on the disease, water treatment may require treating the entire pond or it may be possible to bag the cage in plastic and treat just the cage. Treating the entire pond may be too expensive to be justified, but some parasites can be eliminated only by treating the entire pond. Bag treatment can cause serious oxygen stress if supplemental aeration is not

provided in the bag and should only be used for certain diseases that are not spread from the pond.

Signs of pond stress

Ponds also can be stressed from an accumulation of nutrients and/or from overfeeding. Pond stress in this case is synonymous with water quality problems. Common examples of pond problems are:

- excessive plankton blooms (pea green),
- surface scum,
- strong odors,
- excessive weed growth (macrophytes),
- or a rapid change in water color.

All of these are symptomatic of excessive nutrients and can become problems in any pond as it ages (a process called eutrophication). In most aquaculture ponds it is symptomatic of overstocking and/or overfeeding. Excessive plankton blooms can cause oxygen depletions at night or on heavily overcast days. The same is true of excessive macrophytic growth. Also, surface scum can shade out the rest of the phytoplankton bloom, causing oxygen depletions, and have been identified with off-flavor problems. Strong odors are identified with decaying plant material and usually signal pending oxygen depletions caused by decay. Rapid changes in color also signal phytoplankton die-offs and pending oxygen depletions. In some cases chemical control of the plants may be warranted. In most cases supplemental aeration will be necessary to maintain the fish. At times of severe plankton die-offs



Cages need periodic inspection.

supplemental aeration may not be able to keep oxygen above critical levels in the cage. In these cases it may be necessary to release the fish into the pond hoping that they can spread out and survive, or move them into another pond.

The ability to recognize and prevent potential oxygen problems is usually better than trying to save the fish after the dissolved oxygen has dropped in the pond. Remember that dissolved oxygen stress is one of the chief causes of secondary infections. Contact your local extension director or state fisheries/aquaculture specialist for information on diseases or how to measure and predict dissolved oxygen levels in ponds.

Signs of human error

Of course we could blame ourselves for all of the above, and in most cases we would be justified. Aside from that, common errors made by people include:

- picking ponds with pre-existing problems,
- poor cage construction,
- stocking undersized or poor quality fingerlings,
- stocking too many fish per cage,
- stocking too many fish per pond,
- stocking too few fish per cage,
- feeding poor quality feed,
- overfeeding,
- disturbing and poor handling of the fish,
- and not observing the fish.

These problems are very common, particularly with beginning cage culturists. All of these problems have been discussed in this publication.

Other problems and observations

Biofouling is a common cage problem. Biofouling is the growth of algae and bryozoans (soft bodied, jelly-like animals) on the sides of the cage. These creatures restrict water flow through the cage and cause water quality problems.

Periodically check the sides of the cage (but do not lift the cage out of the water) and remove any biofouling organisms with a stiff brush or broom. Do not stress the fish.

Overwintering in cages is another problem. Some species overwinter better than others, but in general, overwintering should be discouraged. Try to feed your

fish on warm and sunny winter days and be prepared to give medicated feed to the fish if bacterial problems develop in the spring.

All fish farming, including cage production, is “crisis management.” Visit the pond and observe the fish daily. Plan ahead and be prepared for emergencies. If you are inexperienced and a problem arises, get help.

Harvesting and Economics

Being successful at raising fish in cages is not enough. Harvesting, keeping records, marketing, and looking at the economics of the venture are also essentials in successful cage culture. This is particularly true if the goal is to increase farm income.



Another way to harvest fish is to raise the cage out of the water.

Harvesting

Harvesting cages is simply a matter of removing the fish from the cage with a dip net. This is one of the major advantages of cages and usually the reason people picked cage culture in the first place.

Harvesting can begin whenever the fish reach market size. The market size depends on the species being raised and the market that has been identified. Time for fish to reach market size usually depends on the size of the fingerlings stocked and the overall conditions during the growing season. In the case of warmwater fish, harvest usually begins in September or October in the midwestern region. Trout and other coldwater species are usually harvested in March and April. Trout must be harvested before the water temperature rises above 70° F in the spring. Most other warmwater species can be left in cages during the winter months and harvested the following spring when ice goes out.

Fish do not all grow at the same rate. Some fish that reach harvest size early may be removed. However, it should be cautioned that reducing the stocking density by partial harvest, before the water temperature drops to around 60° F, may induce stress and increase fighting among the remaining fish due to the lower density. Fighting also may occur if fish in the cage get too large. Increased fighting may lead to injuries and related bacterial diseases. Before harvesting it is important to sample the fish for possible off-flavor. Off-flavor is caused by more than one agent. Off-flavor is most common in the warmer months but can occur at any time of the year. If the fish taste muddy, musty, oily, or have any strange flavor, you should wait and harvest them at a later date. Off-flavor will go away given time (usually about two week) and good water quality. Your marketing efforts will be harmed if you sell off-flavor fish.

Stop feeding 2 days before harvest. This gives the fish time to empty their digestive systems and reduces holding and processing problems. At harvest, record the number of fish harvested and their weight (length records could also be useful). These records will be necessary to analyze the success of your venture.

Marketing

Ideally, identify your market before you stock, but always plan your market before you harvest. Having no marketing plan will mean frustration and reduce your chance of a profitable venture. Most fish can be sold either live or dress (processed). If you plan to process your fish, you must be in compliance with state health laws. Contact the Department of Health or the fisheries/aquaculture specialist with the Extension Service for information on processing regulations.

Several possible markets exist for your fish. Which markets are best for you may depend on the number or volume of fish you have to sell, your ability to transport the fish, your ability to process the fish, and your proximity to known markets. Possible markets include:

- live sales direct to consumers,
- direct sales to consumers of processed fish,
- live sales to fee-fishing lakes or live-haulers,
- sales to local processing plants,
- and sales to local restaurants or grocery stores.

Small producers, with only a few hundred fish to sell, will probably find their greatest profit in selling directly to the consumer. Direct sales of live or dressed fish reduce retail transportation costs and bring all the profit back to the fish farmer. Live sales at the pond bank or at local farmers' markets also eliminate the need to process the fish. Live sales markets may take a while to develop, but are exceptionally profitable markets.

Fee-fishing, fish-out, or pay lakes are good markets for live fish. Fish-out lakes usually buy fish to stock on a regular basis through the spring and summer and pay premium prices. However, harvesting of your fish in the fall is a problem, in that fish-out lakes may not want to stock too close to winter months. Also, it may be necessary to haul the fish to these fish-out lakes. If you do not have the ability to haul your own fish, you may want to contract with a live-hauler. The live-hauler may buy the fish directly from you or may want a percentage of the sale price.

Finally, if your volume is great enough you may decide to start a processing operation or if you are close to existing processing plants you may wish to sell to them. This latter option is probably the least profitable but is also the most convenient and least time consuming.



Cages allow for predator control.

Whenever marketing farm-raised fish, stress quality and freshness. In the case of cage-raised fish, emphasize that they have been completely away from the mud, that they were grain fed, and that they were grown in a pollution-free environment. Many producers believe that cage-raised fish are better tasting than those raised loose in ponds.

Record keeping

Any business must keep good records to be profitable and successful. Fish farming is no different. Good record keeping is essential to understanding the successes, failures, and profitability of your fish-farming venture. Records that should be kept include:

- cost of cage materials and other equipment,
- cost of fingerlings and their weight and length,
- cost of miscellaneous items (e.g., chemicals, etc.),
- cost of feed and total pounds purchased,
- stocking and harvesting dates,
- number and total weight of fish harvested,
- income from the sale of fish,
- and daily observations of the pond and fish.

Most of the above are self explanatory. The daily observations should include the amount of feed fed, weather conditions, pond conditions, fish appearance, and fish behavior. This information will be invaluable in understanding and predicting problems now and in the future.

Economics

The range of variability throughout the midwestern region in fingerling prices, feed prices, materials and equipment prices, length of growing season, and general weather conditions makes it very difficult to produce good regional budgets.

Fingerling prices for 6- to 8-inch channel catfish, for example, may range from \$0.10 to \$0.55. Feed costs may vary by \$100 per ton or more, depending on volume and location. Live weight price, again for channel catfish, varies from about \$0.70 per pound at large processing plants to \$1.50 or more per pound for direct consumer sales or delivered to fee-fishing lakes.

Table 3 gives some estimates on fixed costs of cage materials and equipment. Cage and equipment costs are usually depreciated over 5 years or more.

Table 4 illustrates approximate production costs calculated on fingerling price and feed price, based on a feed conversion rate of 1.8 (it would take 1.8 pounds of feed to produce 1.0 pound of fish). As with most enterprises there are some economies of size. Cage materials, fingerling costs, and time involved per individual cage all diminish with increasing scale.

Any discussion on economics should probably include emphasizing the risks. Fish farming is a high risk type of agriculture. All agriculture has a degree of risk simply because it is at the whims of nature. This is particularly true of fish farming and cage culture.

Table 3. Fixed costs estimates of materials and equipment for cage culture.

Item	Cost/cage	Cost/5 cages
Cage materials ¹	75.00 ²	160.00
Dip nets	50.00	50.00
Scales ³	45.00	45.00
Miscellaneous ⁴	30.00	65.00
Total	\$200.00	320.00
Total/cage	\$200.00	64.00

¹ Calculated for a 4 x 4 foot cylindrical cage, purchasing only the netting and hoops.

² Calculated buying only an entire roll of netting (50 feet). Two rolls of netting will make 5 cages (second example).

³ Used for weighing fish and feed.

⁴ Includes chemicals, buckets, rope, etc. Cost for aerators is not included. Depending on pond size and stocking density, costs for aeration could range from \$300 to \$1,800.

Table 4. Production costs based on various fingerling and feed prices.¹

Cost per fingerling	Feed Costs (per 50-pound bag)					
	7.20	8.20	9.20	10.20	11.20	12.20
0.10	0.36	0.40	0.43	0.47	0.50	0.54
0.15	0.41	0.45	0.48	0.52	0.55	0.59
0.20	0.46	0.50	0.53	0.57	0.60	0.64
0.25	0.51	0.55	0.58	0.62	0.65	0.69
0.30	0.26	0.60	0.63	0.67	0.70	0.74
0.35	0.61	0.65	0.68	0.72	0.75	0.79
0.40	0.66	0.70	0.73	0.77	0.80	0.84
0.50	0.76	0.80	0.83	0.87	0.90	0.94

¹ Calculated in cents/pounds for producing a 1-pound fish with a feed conversion of 1.8

References

- Basset, B.K. and J.G. Dillard. 1985. *Raising Catfish in Floating Cages*. Cooperative Extension Service, University of Missouri-Lincoln University. 26 pp.
- Beem, M., and G. Gebhart, *Cage Culture of Rainbow Trout*. Langston University. Langston, OK. 4 pp.
- Beveridge, M.C.M. 1987. *Cage Aquaculture*. Fishing News Books LTD. Farnham, Surrey, England. 352 pp.
- Boyd, C.E. 1979. *Water Quality in Warm Water Fish Ponds*. Alabama Agricultural Experiment Station, Auburn University, Auburn, AL. 359 pp.
- Collins, C.M. 1974. *Catfish Cage Culture—Fingerlings to Food Fish*. The Kerr Foundation, Inc., Publication No. 13. Poteau, OK. 22 pp.
- Helfrich, L.A., J.C. Dean, D.L. Garling, and D.L. Weigmann. 1984. *Catfish Farming in Cages in Virginia's Warmwater Ponds and Lakes*. Virginia Cooperative Extension Service, Virginia Tech and Virginia State, Virginia's Land-Grant Universities. 13 pp.
- Schwedler, T.E., M.L. Berry, and D.R. King, 1986. *Raising Catfish in a Cage*. Clemson University Cooperative Extension Service, Clemson University, Clemson, SC. 23 pp.
- Stickney, R.R. 1979. *Principles of Warm Water Aquaculture*. Wiley Interscience, New York. 375 pp.
- Strange, D. and S. Van Gorder. 1980. *Small-scale Culture of Fish in Cages*. Rodale Press, Kutztown, PA. 34 pp.
- Williams, K., D.P. Schwartz, and G.E. Gebhart. 1983. *Small-Scale Caged Fish Culture in Oklahoma Farm Ponds*. Cooperative State Research Service, Langston University, Langston, OK. 25 pp.
- Updated by Rich Clayton, Extension aquaculture specialist, Department of Natural Resource Ecology and Management. (515) 294-8616 rclayton@iastate.edu www.extension.iastate.edu/fisheries/.
- This publication was originally adapted by J.E. Morris, ISU Extension fisheries and aquaculture specialist, and Elaine Edwards, former ISU Extension communication specialist, from Cage Culture Series, no. 160-166, Southern Regional Aquaculture Center, www.msstate.edu/dept/srac/.

... and justice for all

The U.S. Department of Agriculture (USDA) prohibits discrimination in all its programs and activities on the basis of race, color, national origin, gender, religion, age, disability, political beliefs, sexual orientation, and marital or family status. (Not all prohibited bases apply to all programs.) Many materials can be made available in alternative formats for ADA clients. To file a complaint of discrimination, write USDA, Office of Civil Rights, Room 326-W, Whitten Building, 14th and Independence Avenue, SW, Washington, DC 20250-9410 or call 202-720-5964.

Issued in furtherance of Cooperative Extension work, Acts of May 8 and June 30, 1914 in cooperation with the U.S. Department of Agriculture. Jack M. Payne, director, Cooperative Extension Service, Iowa State University of Science and Technology, Ames, Iowa.